

Vaughn's High Voltage Web Site/ ProtoType 1A

300KV 16 Stage Mini Marx

by

Vaughn P. McDowell

CAUTION:

This article is for the purpose of passing information to those persons interested in how I constructed a 300KV Mini Marx generator capable of generating 11 inch lightning bolts. Any one wishing to verify this information should be qualified in safety regarding working with high voltage; construction and material hazard safety and assuming full responsibility for their safety.

ProtoType 1A 300KV Compact 16 Stage Mini Marx

Back in November-December 2007, I decided to construct a general purpose 300KV Mini Marx generator for myself based on reliable prototypes that I built about ten years ago. I decided to pass this information because I am very happy with it; it looks cool, it has been operating reliably for some time, and it is not too expensive to build. The parts can be obtained by the experimenter from the hardware store, McMaster, and Digi-Key. Click on the PDF button for construction details.

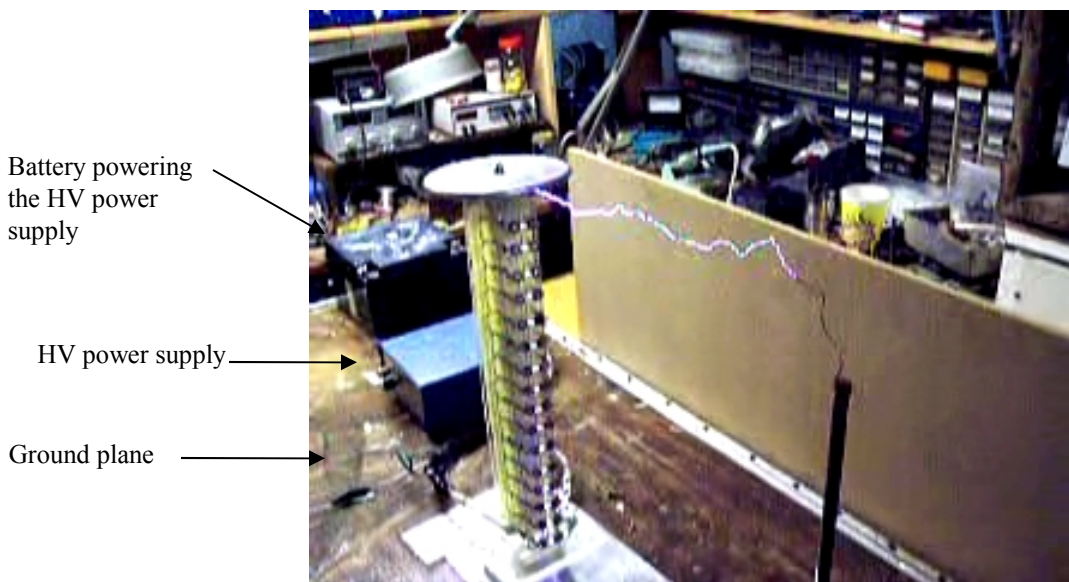

Photo 1: 11 inch bolt

It also shows it sitting on an electrically conductive ground plane charged by a high voltage power supply powered by a 12 Volt battery both of which also rest on the ground plane. Using battery powered HV power supplies is the safest way to go because Marx generators are notorious killers of sensitive electronic instruments including AC powered 12 VDC power supply. For the HV power supply I recommend a low power type powered by 12 VDC input and having an adjustable output from about plus 15 to 20 KV. No more than 20KV should be used.

It is recommended that all photos and illustrations be examined for details regarding the physical component layout. The front view, Photo 2, indicates that the Marx is a 16 stage type being about 16 inches tall. Each of the 16 spark gaps uses paired brass acorn nuts each gapped to about 200 mils. The two vertical resistor capacitor charging rails columns are apparent in Photo 3. With respect to the front the left column is positive and the right negative when a positive output HV power supply is used.

The Marx ground terminal is located at the bottom and the high voltage output uses a brass acorn nut ,located at the top, for attaching an output electrode. The one shown is an aluminum disk with smooth rounded rim that I found in my scrap parts bin. Care should be taken to minimize its output capacitance relative to the Marx's erected capacitance of about 40 pF ([675pf/stage] / 16stages = 42pf.); otherwise the peak output will decrease. The back view shows more clearly the 16 stage capacitor bank located in the vertical mid column; each consisting of four ceramic capacitors.

Photo 2 Front View

Photo 3 Back View

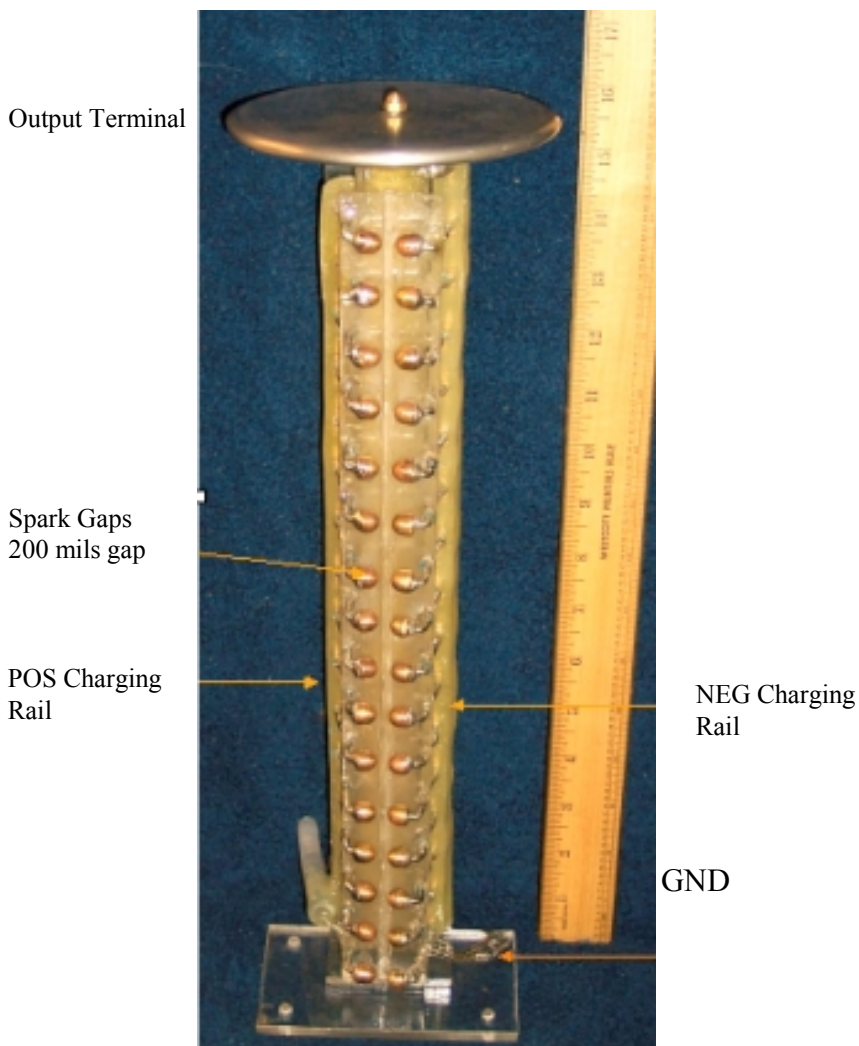

The side view, Photo 4 next page, shows the spark gaps mounted away from the mid section body containing the capacitor bank. Note that the positive charging rail connects to the HV capacitor charging input, consisting of a small horizontal length, located at the bottom of the rail. The HV input terminal is located at the left; its mid section consists of two HV to Marx Allen Bradley 2 W 5.5Meg each isolation resistors which I had in handy in my parts box. These resistors are no longer manufactured as I understand however metal film types can be substituted.

I built this Marx in as small a size that I could manage on a shoe string budget. Doing this made the Marx much more difficult to build than had I used a larger physical layout. To minimize self destructive high voltage tracking and corona leakage for its small size; I encased and potted the resistor charging rails and capacitors. The down side of this is, depending on the potting method, the difficulty is replacing failed components; or worse having to rebuild the whole thing over again.

Obviously this Marx generator can be built using a larger physical form simplifying its construction; making it much easier to replace components when they fail. Also dealing with destructive HV surface tracking can be reduced.

A schematic of this Marx is given in a broken view form to represent the 16 stages. The negative charging rail indicates sixteen 200 K ohm resistors between stages. The positive rail has fifteen 200 K ohm resistors between stages; the sixteenth represents the two 5.5Meg isolation input charging resistor connected in series.

The four ceramic capacitors per stage, previously mentioned, are connected in series having an equivalent capacitance of 675 pF per stage as indicated in the schematic.

The remaining portion of the schematic shows the battery and HV power supply (in block form) connected to the Marx capacitor charging input.

It should be noted that each of the spark gaps were adjusted for about 18KV self break down so that the entire Marx unit self breaks at about 18 KV. The gaps can be adjusted for higher self

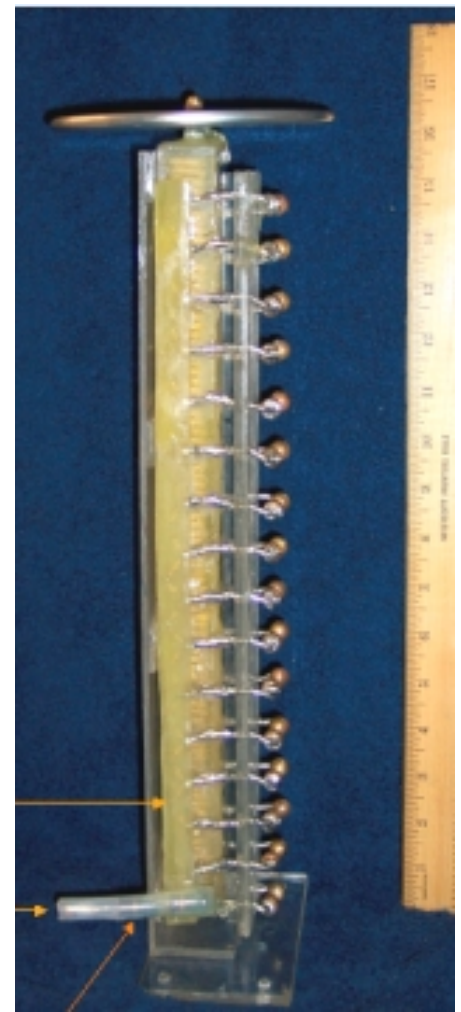

+ Charging Rail
HV charging IN

Input Isolation Resistors

breakdown voltage but I don't recommend more than 20KV; 18-19 KV to be on the safe side. The expected erected voltage is approximately 300KV.

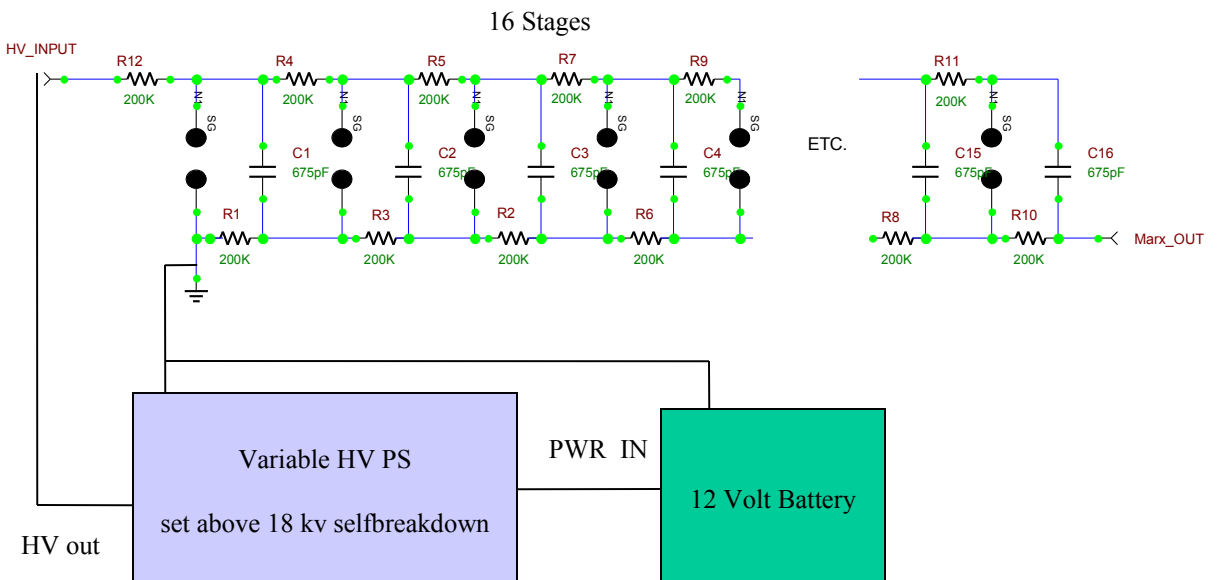

The Panasonic PN ECKA3F272k 2.7nf @3KV capacitors were purchased from Digi-Key ; rated at 3KV; however self destruction has been measured to be about 8KV. When four are connected in series self destruction occurs at about 32KV. Believe it or not the latter configuration seems to have long life when operating around 18 KV .

This Marx requires a minimum of 64 capacitors; I bought them in 100pieces per bag from Digi-Key. The photo at the top right shows a single unit as is; about 0.7 “ dia. and 50 mils thick. The capacitors were prepared by first lining them up and clamping them together; the adjacent capacitors are bonded with super glue. Observing Photos 5 and 6 the leads are arranged as shown; then between stages are cut to length and soldered.; afterward the assembly was cleaned to remove any soldering flux. Finally , see below, the open spaces between the capacitors were filled with epoxy and held in place by wrapping clear plastic transparency around the assembly. Great care was taken making sure to sufficiently cover as well as fill in the space between adjacent soldered leads working out any air bubbles. I didn’t have a vacuum chamber for removing bubbles in the ideal case. It should be noted that the capacitors seem to equalize

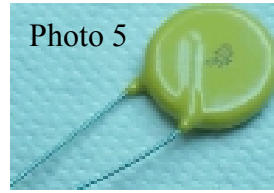
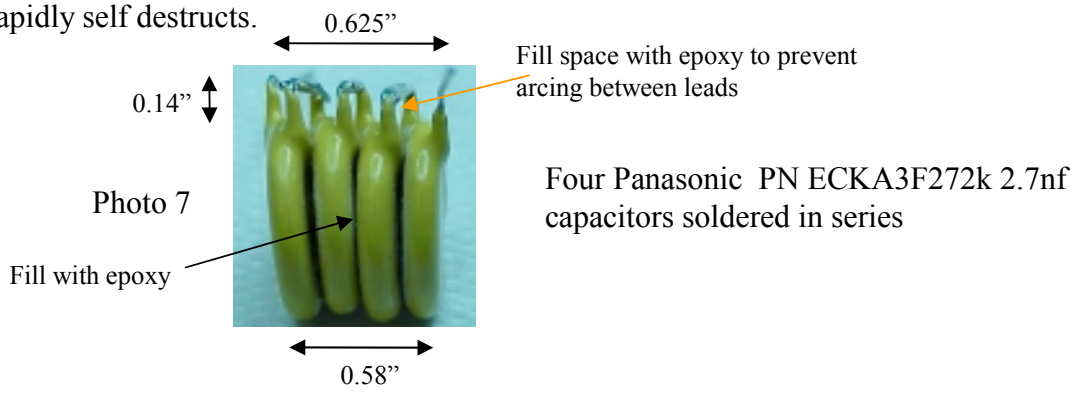

Photo 5



Photo 6

very well without using resistive dividers; however if the adjacent soldered leads are not properly insulated the assembly rapidly self destructs.



The leads at each end (not soldered) of the assembly is the 670pF’s connection leads to the charging rails. After the epoxy is cured the plastic wrap was pulled off from each of the sixteen 670pF Marx capacitor assemblies; each is examined for any flaws. The 670pF assembly was then tested by charging each , through a 20 Meg charging resistor, to 18KV and connecting a self breakdown spark gap to each lead. The 670pF capacitor is subject to a continuous spark gap breakdown for several seconds while closely examining for any tracking of failure. If constructed properly the assembly should operate for quite some time.

After having finished testing all 16 Marx capacitors the capacitor mounting tray was constructed. The capacitors were then assembled and mounted in the tray ,see illustrations 1,2,ans 3 on the next page. The top and end views show thin slots that were carefully cut to width slightly larger than the lead diameter. This allowed the capacitors to bottom out allowing the protruding leads to be normal to the surface.

Referring to the illustrations on page 6 the construction began by cutting acrylic plastic sheets to the size shown (the dimensions may have to be adjusted to fit the capacitors properly). Next the plastic components were assembled by clamping and gluing them using IPS ON 3 WELDING that I purchased on line. It is important that all joints welded are filled as much as possible to minimize any air gaps. When completed the capacitors were placed in the trays; then filled with epoxy a little above the capacitor surface.

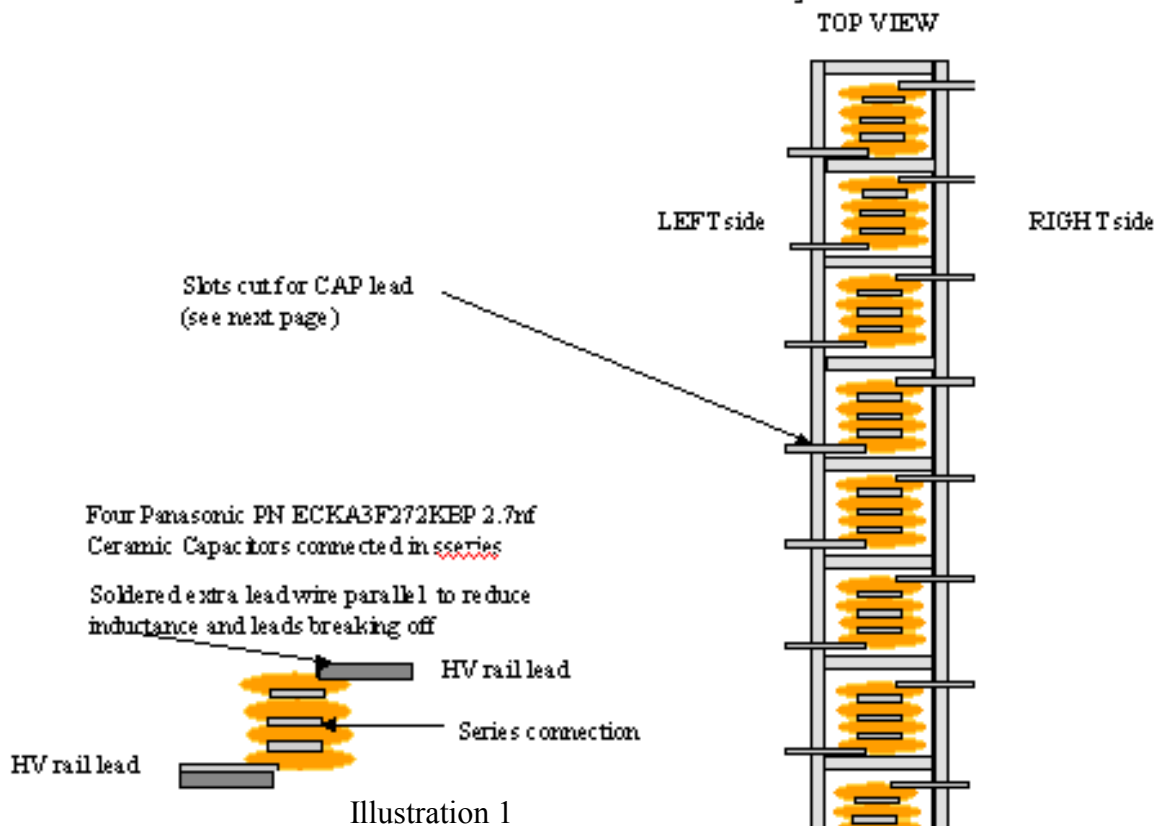

Illustration 1

By studying this and the following page you can see how I mounted the capacitors in the tray. Because no two capacitor assemblies are exactly alike I customized the slot cutouts to match the leads. The slot depth is made so that when the capacitor assembly bottoms with the tray the lead length is minimized:

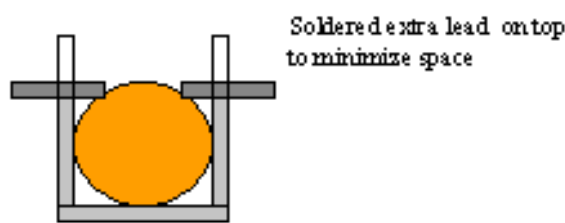

Illustration 2

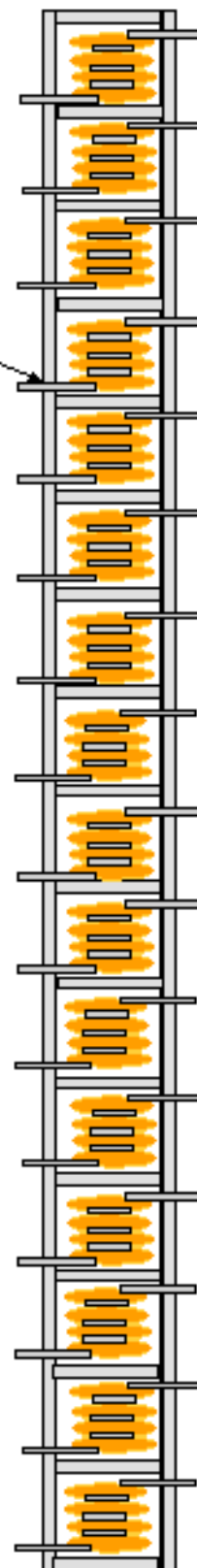

Illustration 3

INSULATIVE CAPACITOR TRAY HOLDER

0.1 inch thick plastic sheet cut to dimensions shown below:

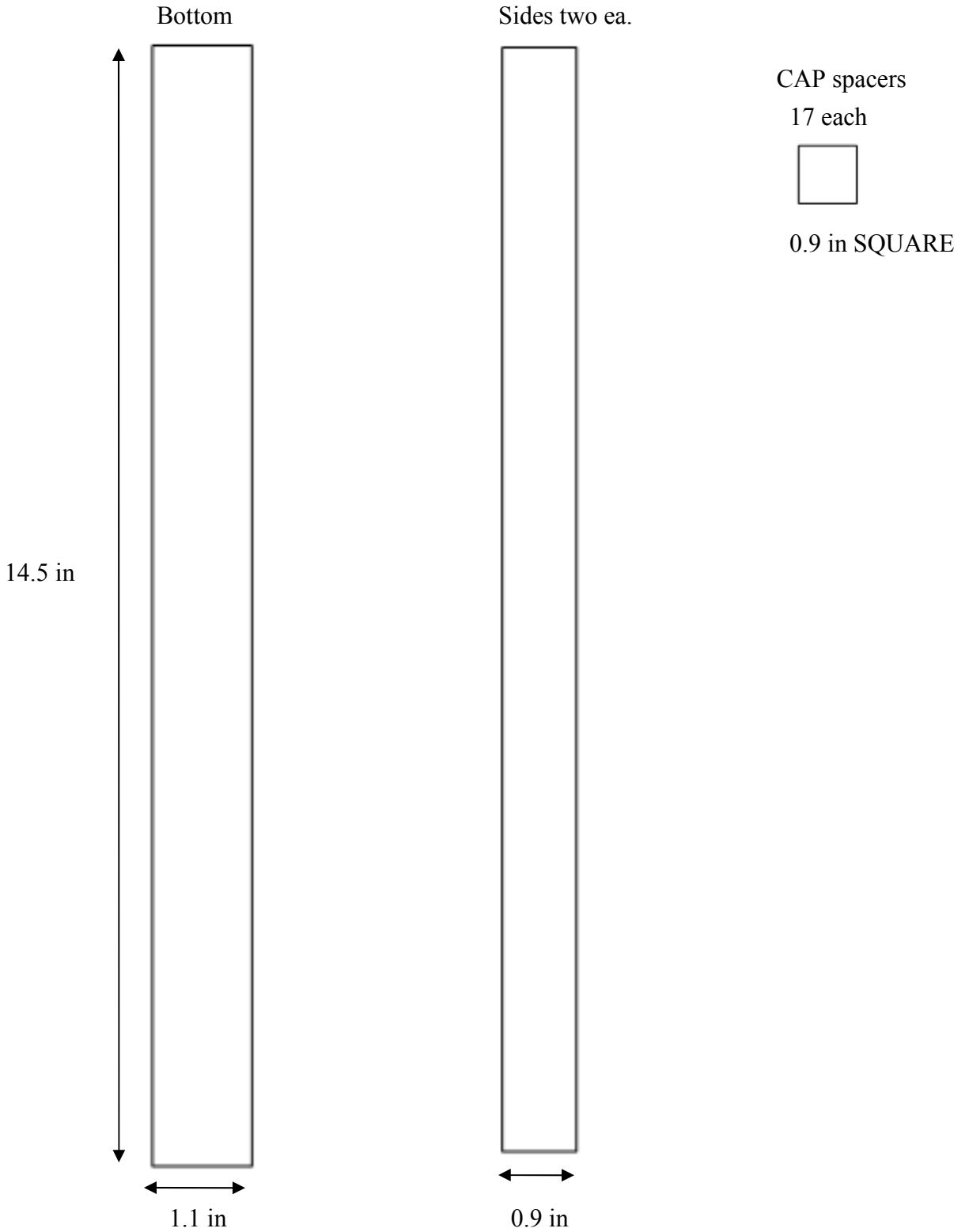

Illustration 4

INSULATIVE CAPACITOR TRAY HOLDER

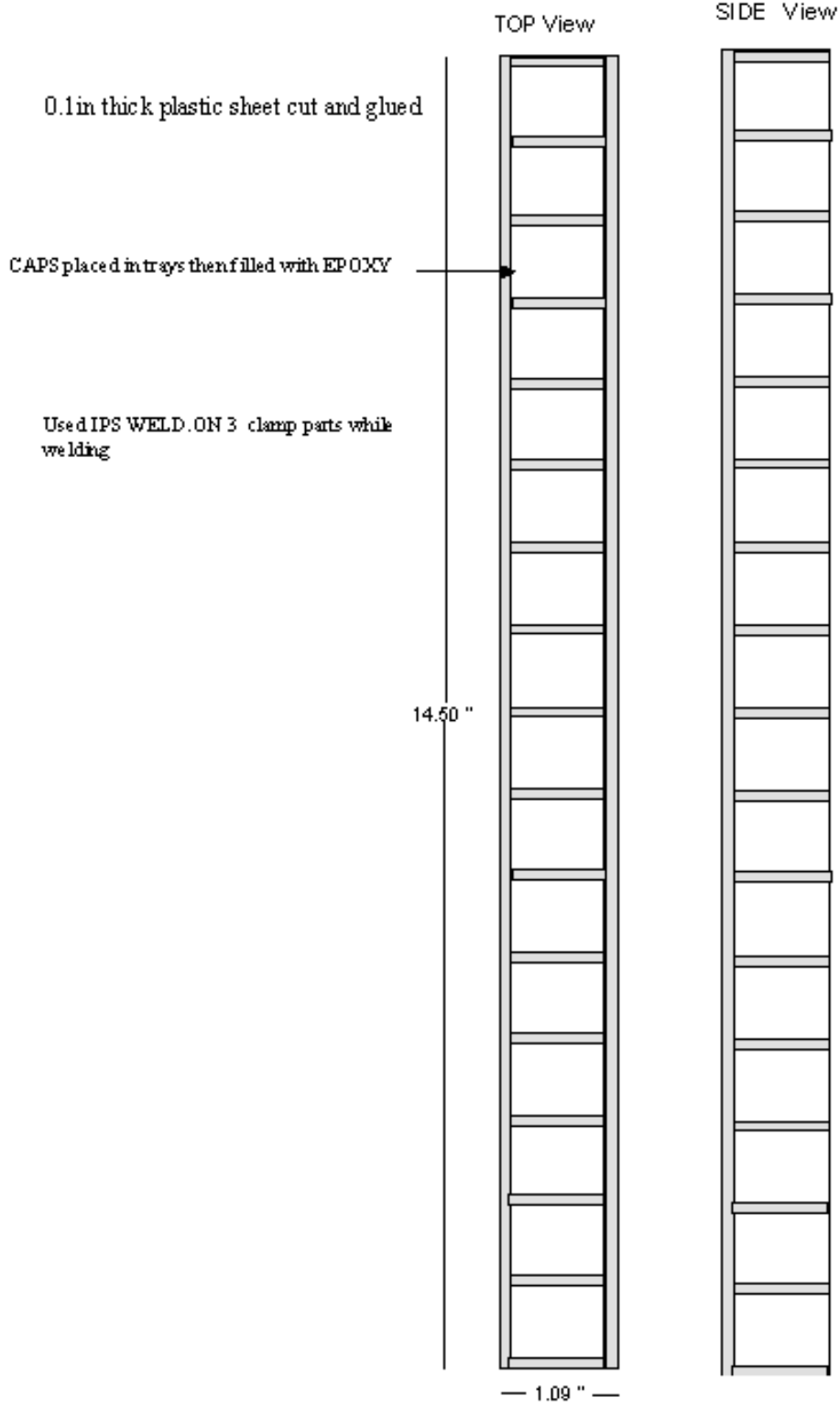
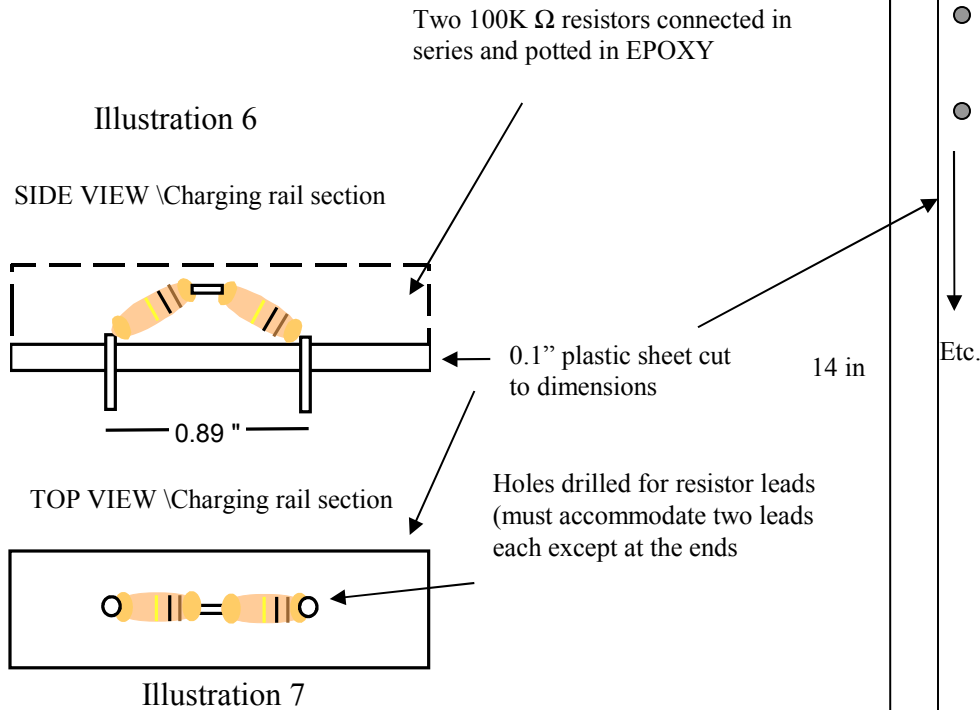

Illustration 5

Capacitor Charging Rail Construction

Examine Illustrations 8, 9, 10, and 11 for details on how I constructed the Marx resistor charging rails. Each has a capacitor charging resistance of 200Kohm per stage; consisting of two 100K 1/2 Watt carbon film resistors (Yageo PN CFR-50JLB purchased from Digi-Key) soldered in series.. See illustration below:



PLASTIC STRIP

Illustration 8

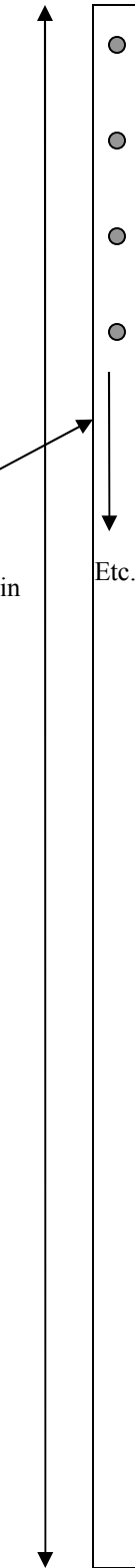

0.5 in

TOP

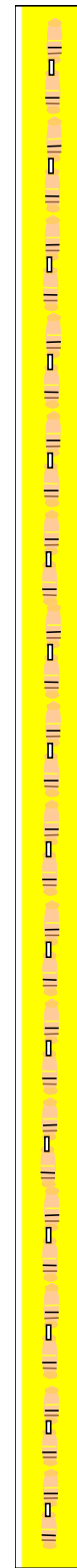

SIDE

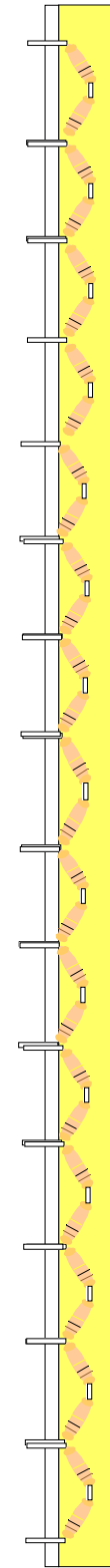

Illustration 9

Looking at the illustrations on this page; two plastic strips were cut to the dimensions shown (0.5 X 12 inches; 0.1 inches thick). Afterwards holes were drilled for mounting the resistor wire leads, as shown above, spaced 0.89 inches; note how the resistors are mounted so as to not lie flat to the plastic surface. Illustration 9 is the top and side view of the resistor rail assembly encased in epoxy (yellow). A temporary mold was made to surround the assembly; so that epoxy could be filled to insulate and enclose the charging resistors (ie 14 X 0.5 X 0.5 inches cube approximately). This was accomplished by taking a sheet of transparency slide and cutting and forming into the required U shape making sure that the sides had sufficient depth to clear the top portion of the resistors (see Illustration 6). It was then temporarily attached to the strip covering the resistors to complete the container so that the epoxy could be poured into it. Enough was used to fill the entire container making sure that all resistors were covered. After the epoxy cured the transparency sheet was pulled off leaving a hardened Marx charging rail structure resembling the top and side illustrations.

Referring to the illustrations at the right, the positive charging rail is shown mounted flush to the side of CAP holder (also Illustration 12 the following page). Notice how the physical location of the capacitor bank's positive electrical connecting leads are lined up and soldered to the electrical leads of the charging rail. I drilled the first hole into the plastic strip at about 0.3 inches from one end.

The negative charging rail is illustrated being attached to the other side of the capacitor bank; see page 10. Take notice how the negative charging rail is mounted one level higher than the positive rail. It should be also noted that the positive rail is shorter than the negative rail; that is because the extra resistor stage is the high voltage 11 Meg input.

Illustration 13 on page 11 shows the front view of the Marx with the positive and negative capacitor charging rails mounted and soldered to the capacitor bank.

The spark gap assembly is illustrated on page 12; a plastic sheet was cut with holes drilled for mounting the spark gaps. Note the slot channel cut in the enter for discouraging high voltage tracking occurring beneath the gaps.

Each of the 16 spark gaps uses paired brass acorn gapped to about 200 mils. During the final stages of the assembly I used a plastic strip several inches long (ideally the full length of the gaps) that is 200mils thick to set and line up the gaps.

The 0.4 in dia. nuts were prepared by cutting and smoothing off and polishing the the surface using a lathe. A approximate 100 mil diameter nails, that I had in my scrap box, were cut and bent as indicated in Illustrations 14 and 15. To keep it from rusting they were covered with silver solder;the head of the nail was then placed and soldered to the acorn nut tapped interior. Copper wire could have been used instead of nails; I chose nails because the gaps would remain fixed and rigid conpared to copper. The 200 mils gapping is intended to protect the capacitors form over voltage.

Illustration 14 shows how each of the nail acorn assembly was inserted into the holes of the plastic sheet. The tips if the cutoff ends of the nails, Illustration 14 were silver soldered to the assembly shown in illustration 13. The final assembly is shown in illustration 15 the side view shows extra plastic strips and backing for support and reducing HV corona and lightning bolts striking sensitive components.

Illustration 10

POS charging Rail

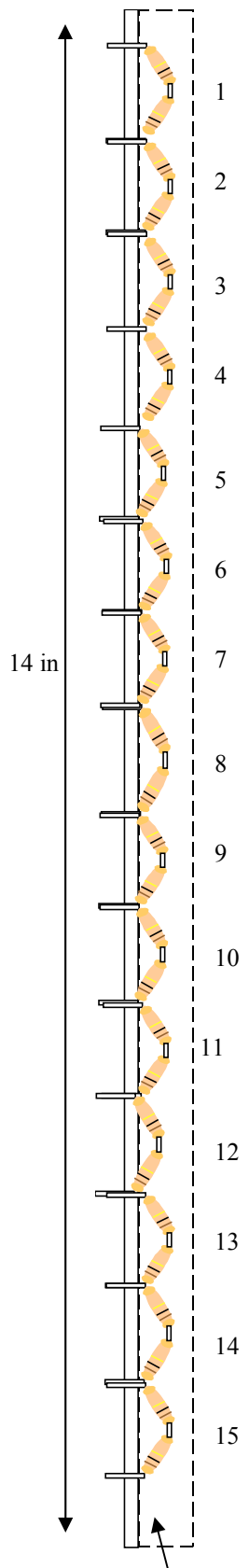

Solder CAP leads to RES leads

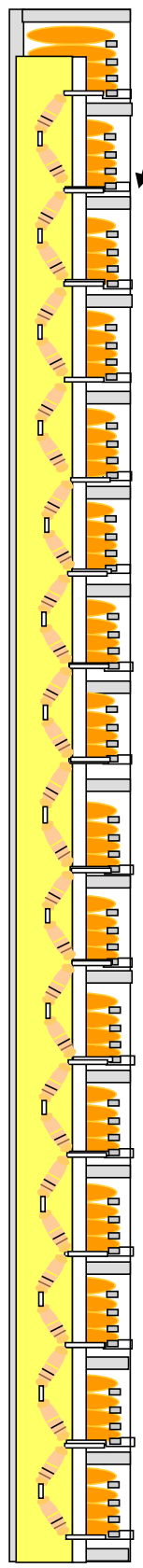

EPOXY Filled

Illustration 11

Marx OUTPUT →

CONSTRUCTION:

Same as POS rail except is longer and has extra charging resistor stage

Illustration 12

14.5 in

GROUND →

NOTE: NEG rail is longer than the POS rail; has extra charging resistor

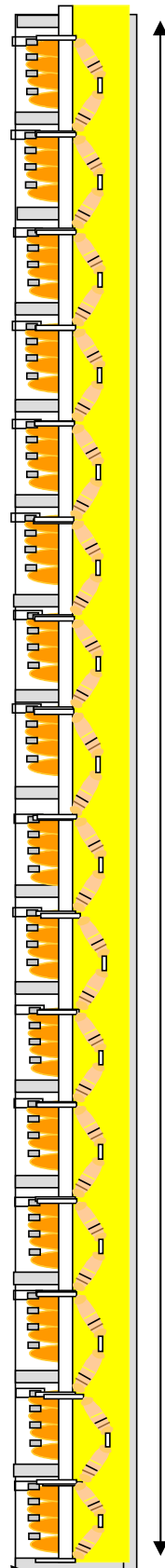

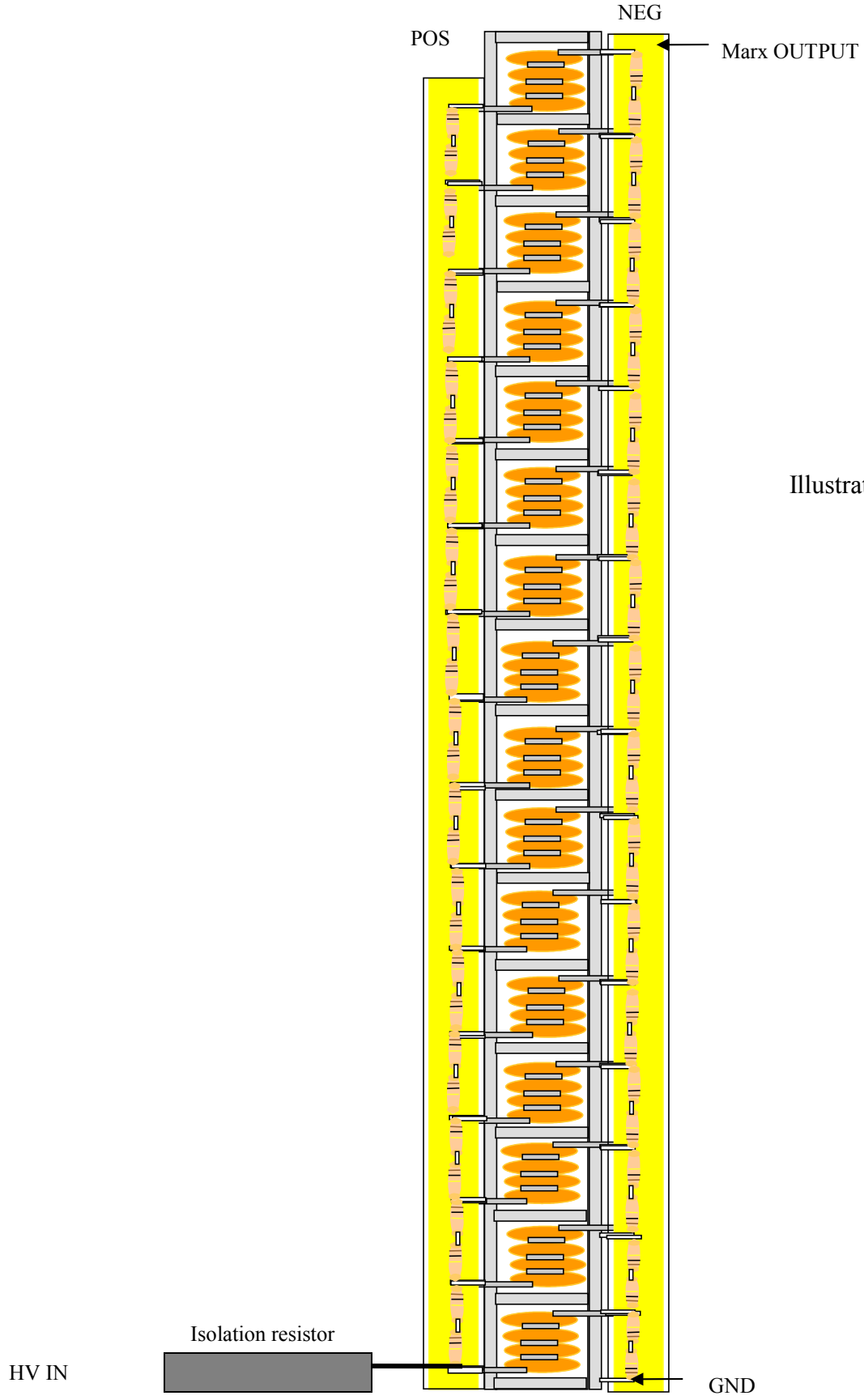

Illustration 13

1.57"

SparkGap ==>> gapped at 200mils

FRONT VIEW

SIDE VIEW

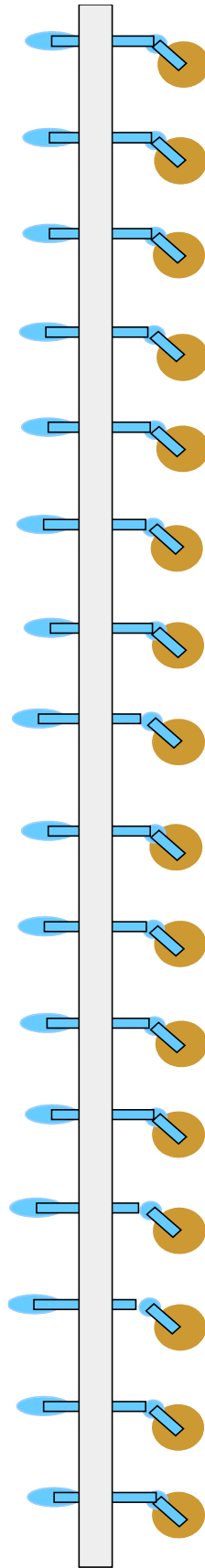
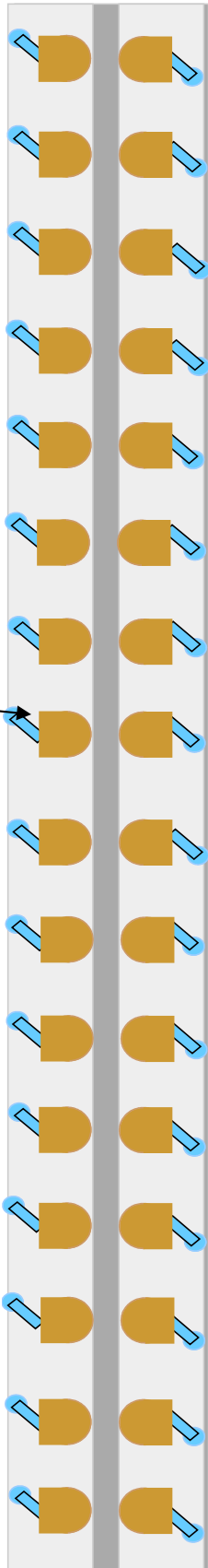

Brass acorn nuts



Illustration 14

